



Ham News

Copyright 1953 by General Electric Company



NOVEMBER-DECEMBER, 1953

VOL. 8—NO. 6

The FIELD METER

A Handy AC-DC Voltmeter, Ohmmeter and SWR Bridge

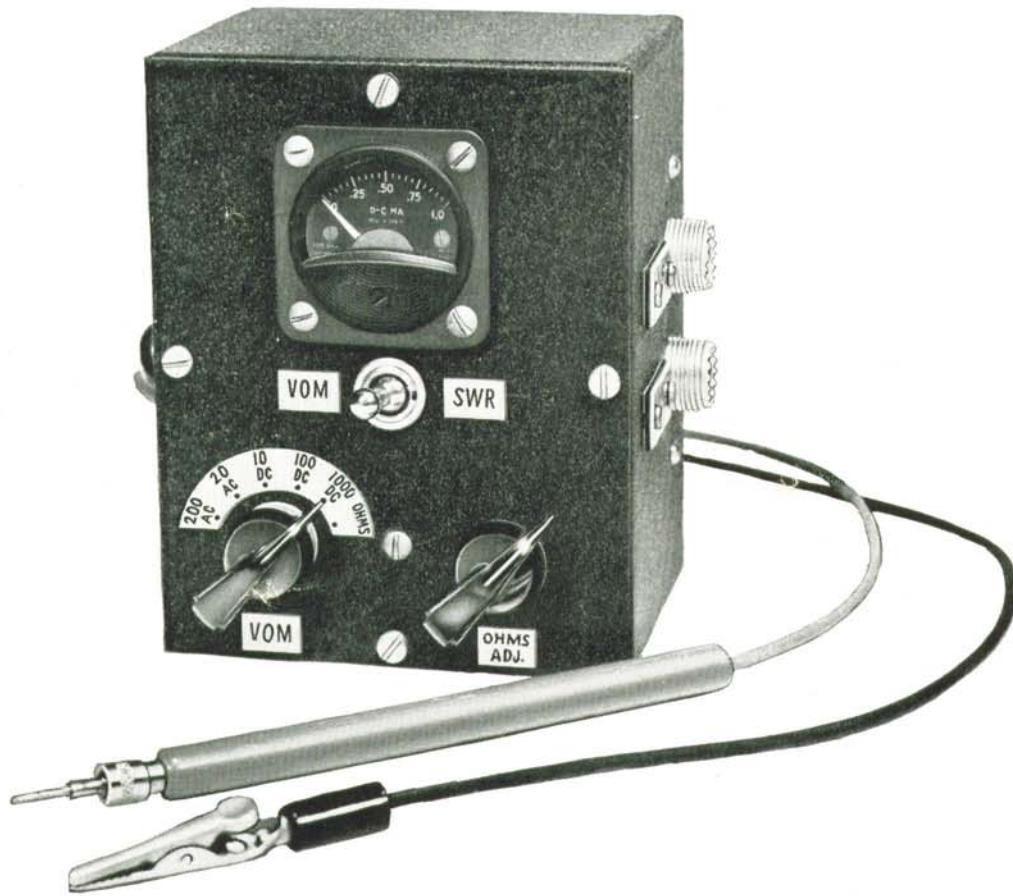

Also—How Tubes Are Numbered—P. 4

Contents

Field Meter	page 2
Tube Type Designation Systems	page 4
Sweeping the Spectrum	page 7
"Operation Bump"	page 8

THE FIELD METER

The idea for the Field Meter was born the hard way—after a particularly tough and disappointing Field Day. The designer—W2FZW—vowed that he would have a capable instrument on his next field operation, one that was not an expensive piece of equipment that had to be treated like a baby.

He listed the minimum field requirements and then set about planning what turned out to be this Field Meter. Its simplicity, versatility and low cost make it a handy gadget to have around the shack. Or perhaps just the simple SWR bridge will be the only part many fellows are interested in.

—Lighthouse Larry

Few hams like to take their pet—and expensive—test instruments on Field Day or vacation. But something adequate often is needed because all too often bench-tested equipment plays tricks under portable conditions. The Field Meter combines field needs in an unusual and relatively simple and inexpensive way.

A 200-volt a-c range permits checking primary and control circuit operation. A 20-volt a-c range allows checking filament or heater voltages of nearly any tube combination encountered. A 10-volt d-c range can be used to check battery voltages and cathode bias in audio or receiver circuits. Incidentally, if 100-ohm resistors are inserted in supply leads to tubes, this 10-volt d-c range can be used to check currents up to 100 milliamperes by measuring voltage drops. (A curve for this could easily be drawn.)

The 100-volt d-c range will check modulator or transmitting tube biases. The 1000-volt d-c range will check plate voltages. The ohms range (1500 ohms center scale) is primarily for continuity checks, but can be calibrated to read fairly accurately in the range of 0-20,000 ohms if desired.

DESIGN CONSIDERATIONS

Accurate VOM-calibration—and precision resistors—were not considered necessary in an instrument whose principal purpose is trouble-shooting. Circuits usually do not stop working because some voltage is 10 per cent off design value, but rather because failure of a component has drastically changed the voltage at some point.

A word of caution. Do not try to simplify the a-c voltage circuit by using a single diode for a half-wave rectifier. The two-diode rectifier shown is necessary to withstand the excessive a-c back voltage which appears when the meter is used on 200 volts a-c.

THE SWR BRIDGE

The Standing Wave Ratio Bridge in the Field Meter is tremendously useful in field operations. The impedance of an antenna changes with its surroundings, height above ground, and many other things. Thus it is particularly important—especially with portable antennas and equipment—to have some means of checking results as reactance and impedance are adjusted to a value that is easily handled by the transmitter.

It is practical for portable operations to design the transmitter to work into 50 ohms resistance—fixed coupling—and then make all field adjustments by means of an antenna coupler to obtain the required 50-ohm load for the rig. With the SWR bridge, this is but a few minutes' work and guarantees top performance, RF-wise. Incidentally, the same bridge circuit can be used for 75-ohm coaxial lines by making R_{11} 75 ohms instead of 51 ohms.

To use the bridge, the transmitter and line cables first are reversed and the input cable loosely coupled to the final tank of the transmitter until full-scale reading of the meter is obtained. Then the cable connections are made as indicated in the schematic diagram. With a 1:1 SWR, the meter reading will be close

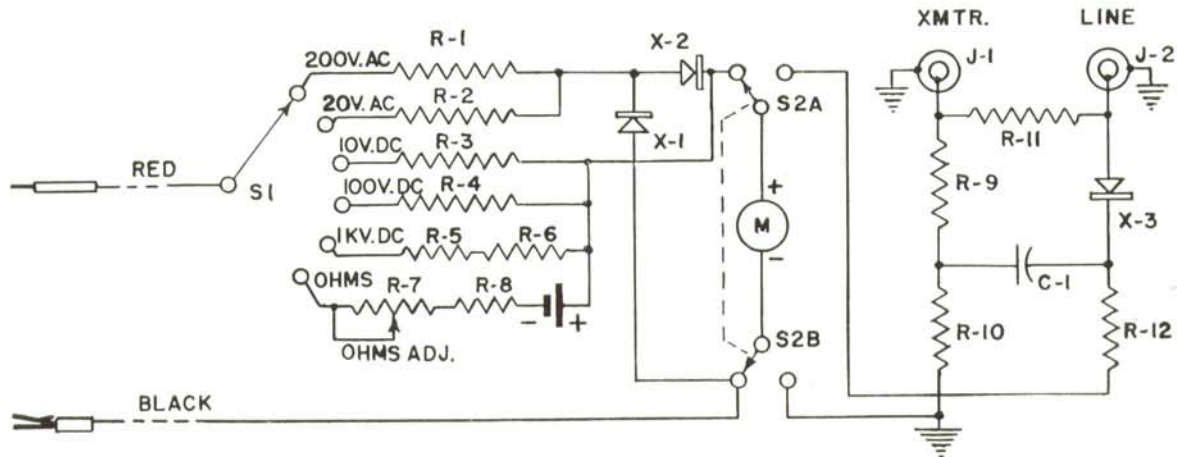

Circuit diagram. All resistors half-watt

C₁—0.005 mfd
 R₁—90,000 ohms (1 megohm in parallel with 100,000 ohms)
 R₂—9000 ohms
 R₃—10,000 ohms
 R₄—100,000 ohms
 R₅, R₆—5 megohm
 R₇—1000-ohm wirewound potentiometer
 R₈—1000 ohms

R₉, R₁₀, R₁₁—51 ohms
 R₁₂—5100 ohms
 X₁, X₂, X₃—1N48 crystal diode
 J₁, J₂—coaxial connector
 S₁—6-position selector switch (Mallory 3226J)
 S₂—DPDT toggle switch
 Battery—1.5-volt cell
 M—0-1 ma. meter

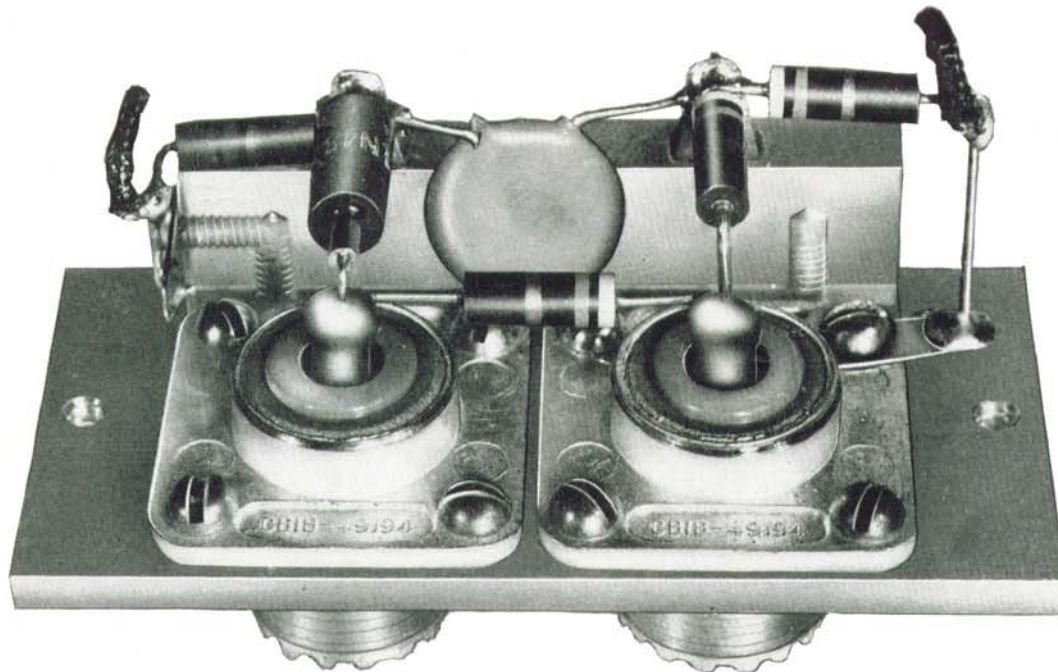

Short leads in the bridge

to zero—in other words, the meter will show a null that indicates perfect match.

A higher meter reading will indicate somewhat less than perfect match. Actually, the bridge may be calibrated for SWR by replacing the transmission line with load resistors of varying values and checking meter readings—making sure to first adjust the loading to precisely full scale each time. For instance, a resistor one-half or twice the value for which the bridge is balanced will give a reading which can be calibrated as a 2:1 SWR. While non-inductive wirewound resistors should be used for calibrating, ordinary composition resistors will give sufficiently accurate calibration to satisfy field needs.

CONSTRUCTION

Construction of the Field Meter was planned so all components except those of the SWR bridge could be mounted on one of the 4 x 5-inch panels of a 3 x 4 x 5-inch utility box. Although it is possible to fit the parts into a smaller box, the panel-mounting type construction makes building and servicing the unit easier and allows all controls to be placed on the front.

Careful placement of the meter, switches, battery and potentiometer are the first job. A handy way to make sure the parts will clear the lip of the box is to draw a half-inch margin around the edge of the inside of the panel. Placement of parts also must allow room for the bridge circuit which is mounted on the two coaxial connectors inside one side of the box as shown in the photographs.

Once VOM parts are mounted, the resistors and diodes associated with the VOM can be wired into

place. As always, care should be taken to correctly polarize the diodes. The G-E 1N48 diodes are clearly marked with the standard crystal diode symbol.

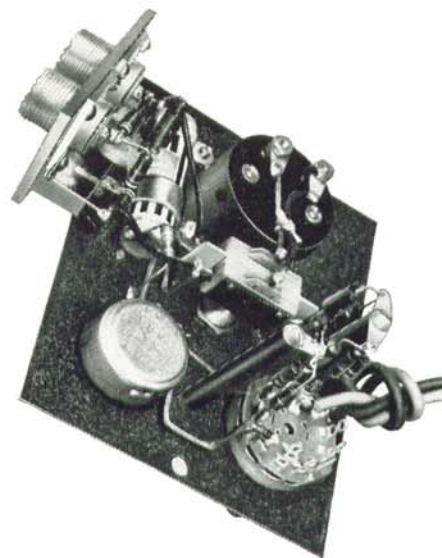

This construction eases wiring job

The FIELD METER (cont'd)

In the model shown, two stand-off insulators made of $1\frac{3}{4}$ -inch lengths of $\frac{1}{4}$ -inch bakelite rod tapped at each end support soldering lugs which act as tie-points for the resistors and diodes of the VOM. Although these insulators are not absolutely necessary, they do give added support which may be of value in an instrument that goes through the trials and tribulations of portable or mobile operation—whether it be Field Day, emergency or vacation.

At first it was planned to mount the coaxial connectors directly on the box—thus building the bridge in place more or less permanently. However, the final design called for a separate mounting plate for the coaxial connectors, thereby allowing the SWR bridge to be built and mounted inside the box as a complete

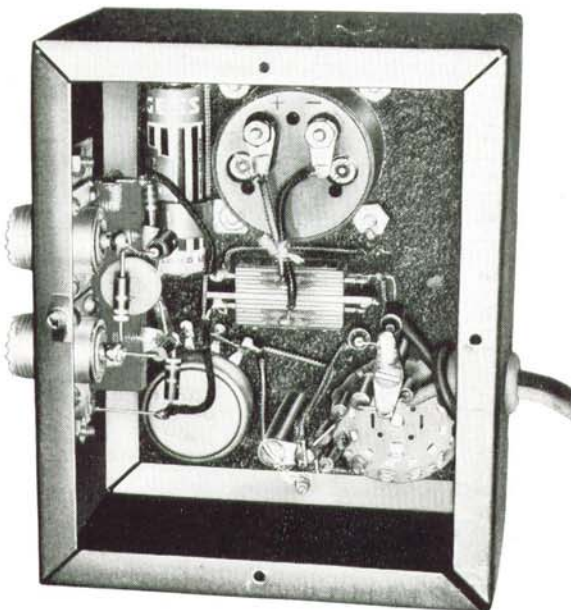

Compact—but not cramped

unit with permanent rigidity, and providing a better RF ground. This plate is of $\frac{1}{8}$ -inch aluminum stock $1\frac{1}{4}$ inches wide and $2\frac{3}{4}$ inches long. The coaxial connectors are mounted with machine screws tapped into the aluminum mounting plate.

A block of $\frac{1}{4}$ -inch polystyrene $\frac{1}{2}$ inch wide and 2 inches long was drilled, tapped and fastened as shown on the edge of the aluminum mounting plate alongside the coaxial connectors with flat-headed machine screws countersunk into the aluminum plate. This block provides two well-insulated tie-points for joining components of the bridge. Actually, ordinary tie-point lugs would probably serve just as well.

The layout and construction shown satisfies the only critical requirement of the instrument—short leads in the SWR bridge itself.

TUBE TYPE

Exceptions prove the rule in numbering

If, as the saying goes, "an exception proves the rule," then the rules governing the designation of radio tubes by numbers and letters are exceptionally well-proved.

For electronic tube numbers are like French verbs—more exceptions than rules. However, believe it or not, there is a system—several of them, in fact—and on occasion it helps to know what the various number and number-letter combinations mean.

Three standard systems now are recognized and used by most tube manufacturers. These are: (1) A receiving type system, (2) a cathode-ray system, and (3) an industrial and transmitting type system. These have been established as standard by a joint committee of two associations of manufacturers—the Radio, Electronics and Television Manufacturers Association (RETMA) and the National Electrical Manufacturers Association (NEMA).

Unfortunately, many tube types pre-date the systems now being used, and as a result we have several hundred cases in currently used tubes where the numbers do not follow the aforementioned systems. Also, some manufacturers still use numbering systems of their own instead of conforming to the voluntary standards set up by the joint committee mentioned above.

A brief review of the current numbering systems and some of those used in the past may help amateurs who, when they browse through a tube manual, get the feeling they are wandering about in an unexplored jungle.

RECEIVING TUBE TYPES

Back in the 1920's, each manufacturer numbered or otherwise named his tubes as he saw fit and things very soon got very messy. The replacement problem was headed toward becoming unsurmountable, and so in 1933 the industry adopted the first voluntary standard numbering system—which although it has been since modified several times—still is used today for receiving tubes. This system calls for a number, a letter, and another number. An example is our old friend, the 6L6.

The first number symbol determines the filament voltage within a certain range, to wit:

Rated Filament or Heater Voltage	Symbol
Zero.....	0
In excess of 0 and up to and including 1.6.....	1
In excess of 1.6 and up to and including 2.6.....	2
In excess of 2.6 and up to and including 3.6.....	3
In excess of 3.6 and up to and including 4.6.....	4
In excess of $n-0.4$ and up to and including $n+0.6$ where n is any integer.....	n

DESIGNATION SYSTEMS

we the rules radio tubes

The letter or letters in the middle are merely serial designations—with two letters being used when manufacturers run out of single letters. Today the letters I, O and P are never used—and also, double combinations such as “AA” are never used.

The final symbol in this system consists of one or more digits which indicate the number of useful elements for which terminals are provided. This includes separate internal shield and shell connections. A few spot checks with the standard base diagrams (which are used in the ARRL Handbook and G.E.’s tube manuals) will show how this final symbol works out.

Often a suffix is used in this receiving type system. These, and their meanings, are: G—glass with octal base; GT—same except with a 1 and 1/8-inch diameter tubular bulb (known as T-9 size); M—metal-coated glass with octal base; X—low-loss base; Y—intermediate-loss base; and W—military type tube. A second suffix—which may be A, B or C and so on—means a superseding version of the same type which, according to the rules of the game, can be plugged into the same socket and should give as good or better performance.



“ . . . things got very messy.”

That is the currently-accepted receiving tube type designation system. But there are many exceptions. Numbers like 41, 80 and 12A carry over from previous years. We find another type of exception in the so-called “loctal” tubes whose designations all begin with a “7”—such as the 7C5. Obviously this plan does not conform to the filament voltage code above. Other exceptions have come about because the original purpose of certain tubes was not for “receiving.” That is, some tubes often are used now for receiving purpose but were originally designed, and numbered, in accordance with some other system. Samples of this type of exception are the 9002 and quite a few tubes in the 5500 series.

CATHODE-RAY TUBES

Being the baby of the family, the cathode-ray tube had a system slapped on it before it was hardly dry behind the filaments. As it now stands, this system calls for a number symbol which tells the maximum diameter or diagonal of the face in inches, a letter which is merely a serial assignment, and a letter-number symbol which designates the type of phosphor used. For example, the 16RP4 has a diagonal of 16 inches and P4 phosphor coating inside the face. However, there are a few exceptions—like the 905, 908, 1803 and so on.

TRANSMITTING TUBES

Under the inglorious heading of “tubes and devices exclusive of receiving and cathode-ray tubes” amateurs will find their favorite transmitting “bottles” labeled with various and sundry letters and numbers which mean little, if anything.

The numbering of transmitting tubes was not standardized until 1942. Thus many tubes still being manufactured carry numbers and/or letters originally assigned under systems started by different manufacturers. For instance, the famous 807 and its brothers and sisters in the 800-series are carry-overs from private pre-war numbering systems. So are tubes in the 200- and 400-series.

In 1942 a standard number-letter-number system for transmitting and special purpose tubes was adopted—a plan which lasted only four years. However, a great many tubes still popular with hams were assigned numbers under this system. Samples are the “Light-house” series like the 2C40 et al, the 4D32, 2E26 and others. Under this system, the first number symbol was assigned to indicate power rating of the heater or filament as follows:

Filament or Heater Power	Symbol
Zero	1
In excess of 0 watts and up to and including 10 watts	2
In excess of 10 watts and up to and including 20 watts	3
In excess of 20 watts and up to and including 50 watts	4
In excess of 50 watts and up to and including 100 watts	5
In excess of 100 watts and up to and including 200 watts	6
In excess of 200 watts and up to and including 500 watts	7
In excess of 500 watts and up to and including 1000 watts	8
In excess of 1000 watts	9

Next, a letter symbol indicated the structure and/or function of the device in accordance with the following schedule:

Type	Symbol
Monode.....	A
Diode.....	B
Triode.....	C
Tetrode.....	D
Pentode.....	E
Hexode.....	F
Heptode.....	G
Octode.....	H
Vacuum capacitors.....	L
Crystal diodes and rectifiers.....	N
Photo-emissive devices, etc.....	P
Mercury types.....	R
Vacuum contactor-type switches.....	S

Finally, a number symbol constituted a serial designation, and these serial numbers started with 21 to avoid conflict with the receiving type designations.

In 1946 this system was scrapped in favor of a pure numerical serial system starting with 5500—the system which is in effect today. Thus many of the newer tubes used by amateurs are appearing with numbers in the 5500's and 6000's. Of course, as this "5500 system"—as it is often called—officially includes special purpose devices, hams will find a great many industrial tubes mixed in with the newer transmitting types of interest in ham operations.

Neither of the two systems outlined—nor any of the private numbering systems—was made retroactive.



"... not the original purpose."

Thus some tubes now bear complex numbers relating to more than one system. This gets a little bulky but does tell the story. Witness the GL-4D21/4-125A. Here the "GL" denotes a General Electric Company tube and the "4D21" and the "4-125A" explain how the tube has been listed under two different numbering systems.

GERMANIUM PRODUCTS

Under the long-hair title "solid state devices" we find one very old friend of the amateur—the crystal diode—and one very new friend—the transistor. While at this writing the numbering system for such devices has not been officially promulgated by the joint designation committee of RETMA and NEMA, there is a system in use—a system which stems from the 1942-1946 transmitting tube system outlined above.

When crystal diodes began to be numbered—such as the 1N51 et al—the first symbol (the number "1") was in accordance with the 1942-1946 code and indicated zero power filament or heater. The second symbol, the "N," indicated a crystal device. The last number was merely a serial designation.

Then the transistor came along and began to carry numbers beginning with "2N—." (G-E junction-type transistors, for instance, are designated 2N43, 2N44 and 2N45.)

Some manufacturers now want to code "solid state devices" by a system which in effect would pick up the pieces of several broken-down systems. They feel that it should go like this: The first number symbol would indicate the number of elements minus one—thus a 1N51 is a diode, a 2N45 a triode and so on; the "N" would indicate a "solid state device"; and the last number would be a serial designation. However, such a coding system has not been officially adopted.

❖ ❖ ❖

As long as this is a free country no manufacturer ever will be bound to adhere to a standard tube numbering system. He can call his tubes anything he likes

However, most manufacturers today do their best to ease the replacement problem by going along with the decisions of the majority on a voluntary basis.

This question sometimes arises: Just who decides precisely what number shall be assigned to a particular tube type under any of the currently-effective designation systems?

The answer is that RETMA registers all tubes upon request of manufacturers, assigning the next open number in the system in question.

❖ ❖ ❖

Now on the basis of the above rules and exceptions could you make up your mind whether or not to use, say, an 862A in your next rig? Chances are you can't—and the chances are, further, that you won't bother to try when you find out that although this bottle has a 200-gallon input rating (and should run cool on the ham bands), it lists at \$1322.00.

SWEEPING *the* SPECTRUM



A new set of TVI problems looms as the new UHF channels come into use. Usually the fault of TVI is not the ham's. But unfortunately our friends and neighbors don't understand the technical problems involved. So it is up to us to tell them, softly and gently (even though it's sometimes awfully tough to hold our tempers). And having told them once is not enough.

Good public relations is no one-shot affair. It has to be a continuing effort consisting of one project after another. Publicity projects, civil defense activities, message handling, emergency work, a friendly smile—all such things improve our relations with the public. And that precisely is what is meant by the somewhat vague-sounding term "public relations."

And continued effort is extremely important. For in this publicity-numbered age, the fellow who does one public service and then stops is soon forgotten.

Our hobby is the only one we know of that is backed by international treaty. (How about private flying?—Ed.) But it won't keep such high standing if the majority of people and their representatives should begin to think our activities aren't worth while. For there are lots of interests ready to move into our frequencies. Let's continue to show people—individually and through our clubs—that we are worthy of our high standing.

✱ ✱ ✱

Speaking of radio clubs, quite a few have been fortunate enough to obtain some kind of vehicle which they are equipping as mobile emergency communications units. In some cases, the vehicle is self-propelled; in other cases it is a trailer which can be hauled about by any auto or truck which may be available in an emergency. Both ideas have merit. But the important thing is to have a good portable or mobile station available.

I mention the subject because it seems not only an ideal way in which amateurs can uphold their tradition and fulfill their responsibilities—but also a relatively easy, efficient, and colorful way of doing the job.

A club communications vehicle project permits pooling the efforts, ideas and equipment of a lot of fellows and gals. And the existence of such a vehicle in a community will be publicly recognized by various official and nonofficial organizations (including the newspapers, if you will only tell them about it). It will be concrete evidence that hams do more than engage in what a lot of people call "silly chatter" that only louses up Milton Berle.

One club member pointed out the big stumbling block in such a project is acquiring the vehicle. He said

he hears such things cost money. And he is so right! Well, where there's a will, there's a way.

Some of the clubs have had such vehicles donated. Luck? Maybe it was pure luck—and maybe not. Maybe a little skull practice and then a few hints in the right direction encouraged such donations. Recently the Atlanta Radio Club acquired a van truck for \$1 from a local organization which preferred to remain unnamed. With all the fine brains in the fraternity, more clubs ought to be able to figure out some angles that would lead to club possession of vehicles that could serve as emergency communications units. The Atlanta Club's truck was second-hand, of course, but it came with a water storage tank, sink, icebox, stove and cabinets. The boys now are installing radio equipment.

✱ ✱ ✱

The editor asked a question the other day that reminded me of something perhaps a lot of hams don't realize. You see, he recently moved to a spot where for the first time in his life he didn't have to bend the ends of a half-wave 80-meter antenna. The switch apparently has awed him and he asked if we thought it would be worth while putting up a long-wire on 80.

It seems his property is long but narrow. We were forced to advise him that unless he particularly wanted gain in that long direction (which he didn't) he ought not to go to any great pains to put up a long-wire. And the reason is that a long-wire gives you more losses than gains. In other words, relatively speaking, the nulls—broadside—of a long-wire probably do more damage in general coverage work than the gain off the end does good. He's still wondering what to put up—and we didn't have the heart to suggest that probably his best bet would be a vertical (which he could have put up on any old lot).

✱ ✱ ✱

Incidentally, the editor was hopping all over us the other day asking where are all these projects we've been promising. Well, honestly, all I can say is that they are in the works. But as you know—if you've ever designed, built, and tested a piece of equipment—it takes time. And because we want to be sure there are no bugs in anything we write up—well, it takes up a little more time than usual. Especially with the Army, Navy and commercial people breathing down our back asking for *their* projects!

— *Lighthouse Larry*

Operation 'Bump'

G-E HAMS TEST A GL-805

G-E electronic tubes go through a series of grueling tests. One of them, shown at right, given to some tubes, is a shock test known in the laboratory as "bumping."

At the far right in the picture L. F. Jeffrey, W2GYV, supervisor of the test laboratory and designer of the "Mobile-Marine Receiver" (G-E HAM NEWS Vol. 7, No. 4), watches A. J. Banas, W2DIS, also of the test lab staff, "bump" a popular ham tube.

The subject of the test is a GL-805, taken from the production line at G.E.'s transmitting and industrial tube plant in Schenectady. The tube is hung by the base with an adjustable clamp. Then a 2-pound weight at the end of a 4-foot rod is lifted to an angle of 25 degrees and let fly. The face of the weight is covered with rubber of a specified resiliency to avoid cracking the glass envelope of the tube. The clip-leads and meter shown are to check for shorts and filament continuity after a bump. Although W2GYV and W2DIS are wearing their safety glasses, they have never seen a G-E tube break in "Operation Bump." Of course, the objective is to test the internal structure rather than the glass.

G-E started "bumping" tubes long before such tests became common specifications in government contracts.



Ham News

Available FREE from

G-E Electronic Tube Distributors

Printed in U.S.A.

A Bi-monthly Publication

TUBE DEPARTMENT

GENERAL  ELECTRIC

Schenectady 5, N. Y.

In Canada, Canada's General Electric Company, Ltd., Toronto, Ont.

S. E. McALLUM, W2ZBY—EDITOR

Distributed By
ALLIED RADIO CORP.
100 N. Western Ave.
CHICAGO 80, ILL.
Phone HAYmarket 1-6800

K4XL's **BAMA**

This manual is provided **FREE OF CHARGE** from the "BoatAnchor Manual Archive" as a service to the Boatanchor community.

It was uploaded by someone who wanted to help you repair and maintain your equipment.

If you paid anyone other than BAMA for this manual, you paid someone who is making a profit from the free labor of others without asking their permission.

You may pass on copies of this manual to anyone who needs it. But do it without charge.

Thousands of files are available without charge from BAMA. Visit us at <http://bama.sbc.edu>